

CASINA (SINGLE/DOUBLE) INSTALLATION GUIDE

This product must be fitted only by a fully qualified installer.

DESCRIPTION	DESCRIPTION	ILLUSTRATION
 	Fixing choose the appropriate fixing for the wall material if required	
	PTFE tape	
	Electric drill	
	Masonry drill bit appropriate to the fixings	
	Adjustable spanner	
	Radiator valve hex key	
 TOP - RIGHT CLIPS x 1	 TOP - LEFT CLIPS x 1	Flat head and philips head screw drivers
 BOTTOM - RIGHT CLIPS x 1	 BOTTOM - LEFT CLIPS x 1	1 lock shield valve and 1 gate or thermostatic valve
 END PLUG x 1	 FIXING SCREWS x 4	 Spirit level
 WASHERS x 4	 MEASURING TAPE	 Measuring tape
 AIR VENT x 1	 WALL ANCHORS x 4	
 GASKETS x 4		

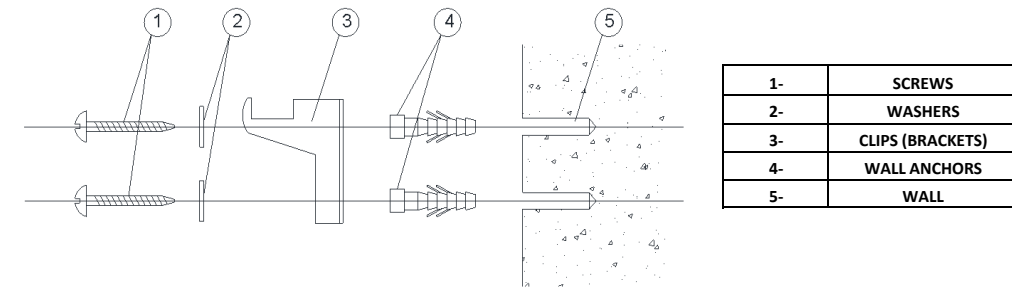

1-	SCREWS
2-	WASHERS
3-	CLIPS (BRACKETS)
4-	WALL ANCHORS
5-	WALL

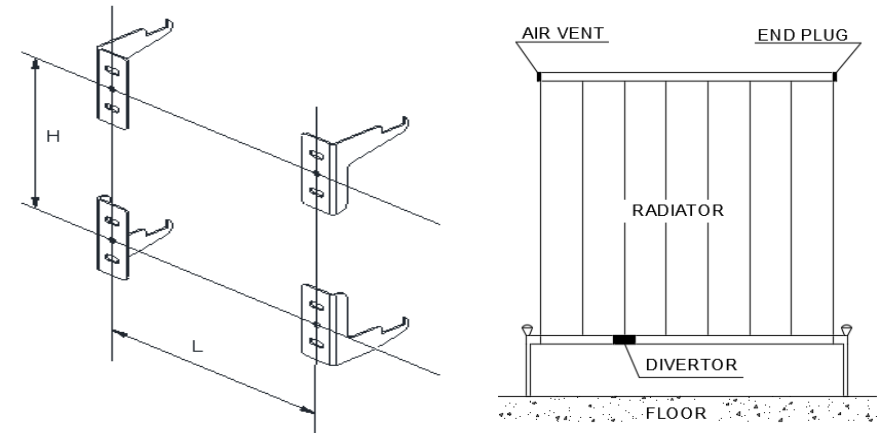

NAMES	A	B	C	TUBE QTY	DA	DM	DD	H	L
CASINA (SINGLE)	600	470	545	5	25	34	65	480	247
CASINA (SINGLE)	600	660	545	7	25	34	65	480	247
CASINA (SINGLE)	600	850	545	9	25	34	65	480	437
CASINA (SINGLE)	600	1040	545	11	25	34	65	480	627
CASINA (SINGLE)	600	1230	545	13	25	34	65	480	817
CASINA (SINGLE)	600	1420	545	15	25	34	65	480	1007
CASINA (SINGLE)	1800	280	1745	3	25	34	65	1680	57
CASINA (SINGLE)	1800	375	1745	4	25	34	65	1680	152
CASINA (SINGLE)	1800	470	1745	5	25	34	65	1680	247
CASINA (SINGLE)	1800	565	1745	6	25	34	65	1680	342
CASINA (DOUBLE)	600	470	545	5	25	55	86	480	247
CASINA (DOUBLE)	600	660	545	7	25	55	86	480	247
CASINA (DOUBLE)	600	850	545	9	25	55	86	480	437
CASINA (DOUBLE)	600	1040	545	11	25	55	86	480	627
CASINA (DOUBLE)	600	1230	545	13	25	55	86	480	817
CASINA (DOUBLE)	600	1420	545	15	25	55	86	480	1007
CASINA (DOUBLE)	1800	280	1745	3	25	55	86	1680	57
CASINA (DOUBLE)	1800	375	1745	4	25	55	86	1680	152
CASINA (DOUBLE)	1800	470	1745	5	25	55	86	1680	247
CASINA (DOUBLE)	1800	565	1745	6	25	55	86	1680	342

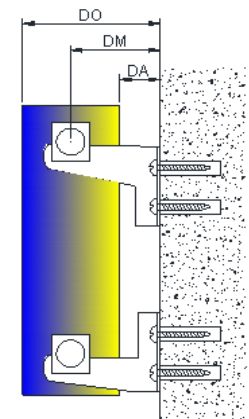

GENERAL RECOMMENDATION

- Before fitting the radiator it is necessary to wash out the heating system to remove any existing mud, scale, work residues, traces of flux, oil, etc.
- When the system water pH is outside the 5,5-8,5 range and/or when the dissolved is above 0,1mg/liter, it is always needed to protect the heating system components (the radiator is one of these) with a proper chemical treatment compatible with all parts in contact with water (silicon rubber too).
- In order to fit the radiator to the wall, it is necessary to choose the proper fixings for the wall material.
- If the system water exceeds 50°C, please install a warning mark near the radiator to avoid any accidental scalding.
- Clean the radiator surface only with a soft cloth to avoid scratching the finish and do not use chemical agents during cleaning operations. It is prohibited to climb on the radiator.
- Maximum working temperature 95°C, maximum working pressure 4 bar.